

GENERAL DESCRIPTION

The ADIS16080/PCB is a simple evaluation board that provides convenient access to the ADIS16080 using a standard 2mm, 2x6, connector interface. These connectors can be accessed using a variety of cable options, including standard 1mm ribbon cables. The ADIS16080/PCB is designed to be evaluated in an existing digital platform (MCU, DSP, FPGA, PLD, etc) or as part of the ADISEVAL system. Four mounting holes (sized for 2-56 or 2mm screws) have been provided to secure the board during evaluation.

CIRCUIT DESCRIPTION

The schematic, layout and parts list for the ADIS16080/PCB can be found in Figure 1, Figure 2, and Table 1.

The ADIS16080's digitized outputs can be accessed using the 4-wire serial port interface (SPI) signals on J1: SCLK, CS, DOUT and DIN. For specific information on using the ADIS16080's SPI interface, refer to the ADIS16080 datasheet. Auxiliary functions, such as the two 12-bit ADC inputs, can be accessed using J2. C1 and C4 provide additional filtering for the two different power supply inputs (Vdrive and Vcc). The ADIS16080's reference voltage is filtered by C2.

Table 1 – ADIS16080/PCB Parts List

Reference Designator	Part Description
U1	ADIS16080ACCZ
J1,J2	Connector, 12-pin, dual row, 2mm
C1, C4	Power supply filtering, not installed
C2	Vref filtering, not installed
C3	Bandwidth reduction, not installed

SPECIAL NOTES ON HANDLING

Note that the ADIS16080/PCB is not reverse polarity protected. Reversing the power supply or applying inappropriate voltages to any pin (outside the Absolute Maximum Ratings in the ADIS16080 data sheet) may damage the ADIS16080/PCB.

Table 2 – Power Supply Levels

Vcc	+4.75V to +5.25V
Vdrive	+2.7V to +5.25V

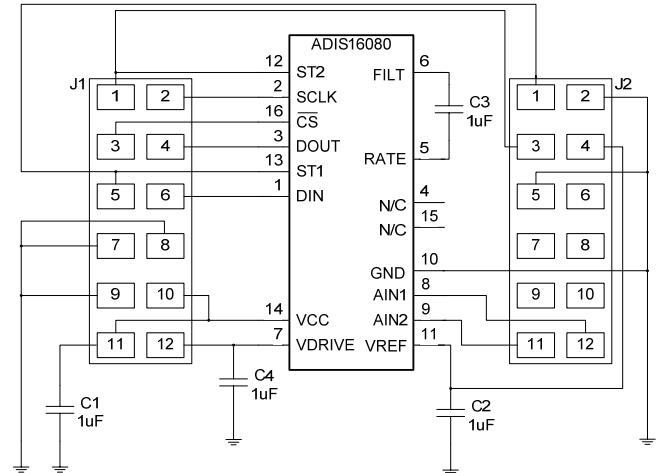

Figure 1 - ADIS16080/PCB Schematic

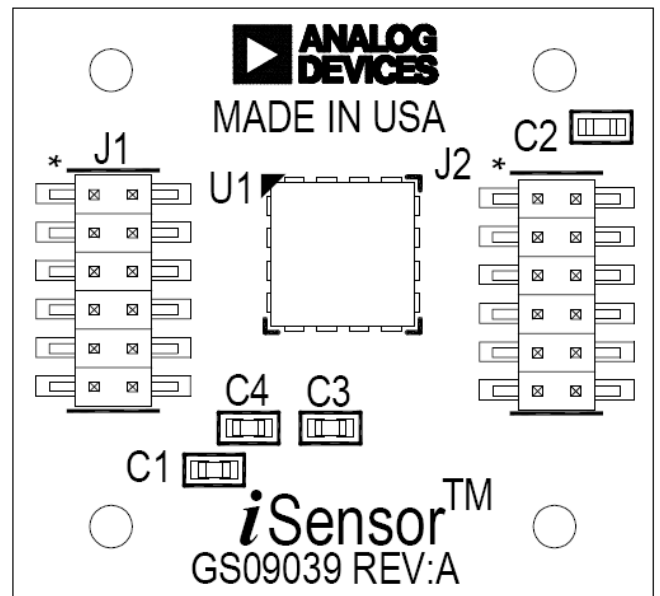

Figure 2 - ADIS16080/PCB Layout (Top View)

ORDERING GUIDE

Model	Package Description
ADIS16080/PCBZ	Evaluation Board, RoHS Compliant
ADISEVAL	iSensor™ PC Evaluation System